

Stainless Steel, Welded Seal Shear Beam Load Cell

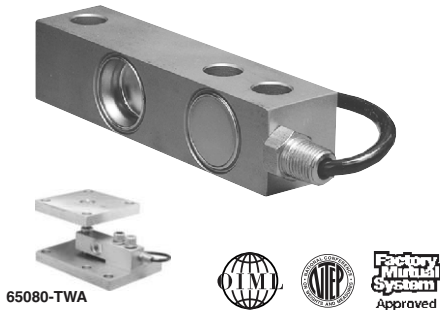

- Rated capacities of 1000 to 20,000 pounds
- Stainless steel, welded seal construction
- Trade certified for NTEP Class III L 10000 and III 5000 divisions and OIML R-60 3000 divisions
- Hostile or clean environment
- *Sensorgage*™ sealed to IP67 standards
- Factory Mutual System Approved for Classes I, II, III; Divisions 1 and 2; Groups A through G. Also, non-incendive ratings (No barriers!).

DESCRIPTION

Model 65083 provides the weighing industry with excellent protection necessary for today's hostile environments in an economical low profile range suitable for platform scale manufacture.

Its low profile and all welded sealing combined with high accuracy makes this load cell ideally suited for low profile platforms, pallet truck weighers, tanks and silos. The guide slots incorporated into the upper and lower mounting faces enable manufacturers to easily position the load cell.

Hermetically sealed against moisture, the construction of the model 65083 in combination with a polyurethane dual shielded cable, enables continuous operation in harsh environments while maintaining a high operating specification.

The two additional sense wires feed back the voltage reaching the load cell. Complete compensation of changes in lead resistance due to temperature change and/or cable extension, is achieved by feeding this voltage into the appropriate electronics.

FEATURES

OPTIONAL FEATURES

- Companion weigh module available 65080 Stainless Steel *TantaMount*
- Integral conduit adaptor with teflon jacketed cable available

APPLICATIONS

- Hostile environments: Food & beverage processing
Chemical and plastics processing
Pharmaceutical and biomedical processing
- Tank, bin and hopper weighing
- Batching, blending and mixing systems

OUTLINE DIMENSIONS in inches

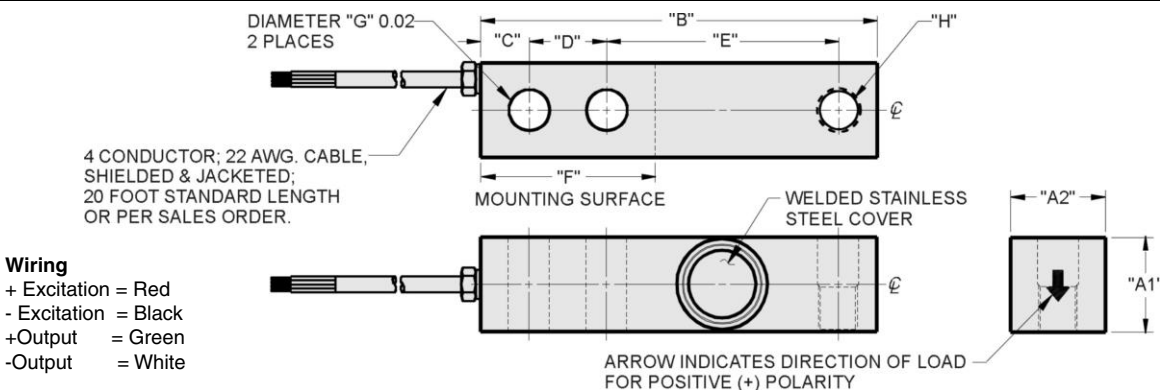

CAPACITY	A1	A2	B	C	D	E	F	G	H	DEFLECTION	WEIGHT
1K - 4K	1.22	1.22	5.12	0.62	1.00	3.00	2.25	0.53	1/2-20 UNF-2B, Ø 0.53 x 0.61 DEEP C'BORE	0.008 - 0.026	4.0
5K - SE*	1.22	1.22	5.12	0.62	1.00	3.00	2.25	0.53	1/2-20 UNF-2B, Ø 0.53 x 0.61 DEEP C'BORE	0.008 - 0.026	4.0
5K - 10K	1.50	1.50	6.75	0.75	1.50	3.75	3.00	0.78	3/4-16 UNF-2B, Ø 0.78 x 0.75 DEEP C'BORE	0.030 - 0.055	6.5
15K - 20K	2.00	2.00	8.75	1.00	2.00	4.88	4.00	1.06	1-14 UNS-2B, Ø 1.06 x 1.00 DEEP C'BORE	0.025 - 0.032	9.0

Capacities are in pounds. Deflection is ±10%. Certified drawings are available.
* SE denotes "Small Envelope". A 5K capacity is available in the 1K/4K dimensional envelope.

SPECIFICATIONS					
PARAMETER	VALUE				UNIT
Rated capacity-R.C. (E_{max})	500, 1K, 1.5K, 2K, 2.5K, 4K, 5K, 10K, 15K, 20K ⁽¹⁾ 250kg, 500kg, 750kg, 1t, 2t, 5t, 10t ⁽¹⁾				lbs kg/metric tons
NTEP/OIML Accuracy class	NTEP III	NTEP IIIIL	Standard	OIML R60	
Maximum no. of intervals (n)	5000 single	10000 multiple		3000 ⁽¹⁾	
$Y = E_{max}/V_{min}$	NTEP Cert. No. 98-175			8333	Maximum available
Rated output-R.O.	2.0	2.0	3.0	2.0	mV/V
Rated output tolerance	0.25				±% mV/V
Zero balance	1.0				±% FSO
Combined error	0.02	0.02	0.03	0.02	±% FSO
Non-repeatability	0.1				±% FSO
Creep error (30 minutes)	0.025	0.03	0.03	0.017	±% FSO
Temperature effect on zero	0.0010	0.0010	0.0015	0.0010	±% FSO/°F
Temperature effect on output	0.0008	0.0008	0.0008	0.0007	±% of load/°F
Compensated temperature range	14 to 104 (-10 to 40)				°F (°C)
Operating temperature range	0 to 150 (-18 to 65)				°F (°C)
Storage temperature range	-60 to 185 (-50 to 85)				°F (°C)
Sideload rejection ratio	500:1				
Safe sideload	100				% of R.C.
Maximum safe central overload	150				% of R.C.
Ultimate central overload	300				% of R.C.
Excitation, recommended	10				Vdc or Vac rms
Excitation, maximum	15				Vdc or Vac rms
Input impedance	343 - 357				Ω
Output impedance	349 - 355				Ω
Insulation resistance at 50VDC	>1000				MΩ
Material	Stainless steel				
Environmental protection	IP68				
Recommended torque	All capacities up to 5000kg - 136.0 5000kg - 205.0				N*m

Notes

⁽¹⁾ OIML approval 1-10K & 500-5000kg only
NTEP approval 1-10Klbs only (kg/metric capacities are not approved)

FSO - Full Scale Output

All Specifications subject to change without notice.